



User guide and installation manual

Air Conditioning Multi-Head Ultra indoor unit

ACV28W, ACV36W, ACV45W,
ACV56W, ACV71W, ACV84W



IMPORTANT NOTICE

Please read this manual before installing the product and retain for future use. Not following the instructions may result in the product not functioning as intended.

Installer information

Installer company:

Contact number:

Installer full name:

Install date:

Notes:

Important information

- Emerald pursues a policy of continuing improvement in design and performance of products. We reserve the right to change specifications without notice.
- Emerald cannot anticipate every possible circumstance that might involve a potential hazard.
- This heat pump air conditioner is designed for standard air conditioning only. This unit is not intended for purposes such as drying clothes, storing food, or any other process beyond standard heating or cooling.
- The installer and system specialist shall secure safety against leakage according to local regulations or standards. The following standards may be applicable if local regulations are not available. British Standard, BS4434 or Japan Standard, KHKS0010.
- This product is a partial unit air conditioner, complying with partial unit requirements of this International Standard, and must only be connected to other units that have been confirmed as complying to corresponding partial unit requirements of this International Standard.
- No part of this manual may be reproduced without written permission.
- Signal words (DANGER, WARNING and CAUTION) are used to identify levels of hazard seriousness. Definitions for identifying hazard levels are provided below with their respective signal words.

DANGER

Immediate hazards that WILL result in severe personal injury or death.

WARNING

Hazards or unsafe practices that COULD result in severe personal injury or death.

CAUTION

Hazards or unsafe practices that COULD result in minor personal injury or product or property damage.

NOTE

Useful information for operation and/or maintenance.

- It is assumed that this heat pump air conditioner will be operated and serviced by English speaking people. If this is not the case, safety, caution and operating signs should be added in the native language.
- If you have any questions, contact your distributor or dealer of Emerald.

- This manual gives a common description and information for this heat pump air conditioner which you operate as well as for other models.
- The lowest moving part should be installed at least 2.5m (8.2ft.) above floor level.
- Refer to Installation and Maintenance Manual of outdoor unit for temperature operation range.
- This manual should be considered as a permanent part of the air conditioning equipment and should remain with the air conditioning equipment.

The model pictures in this manual are only for illustration. Please refer to the actual appearance.

Correct disposal



This marking indicates that this product should not be disposed with other household wastes. To prevent possible harm to the environment or human health from uncontrolled waste disposal, recycle it responsibly to promote the sustainable reuse of material resources. To return your used device, please use the return and collection systems or contact the retailer where the product was purchased. They can take this product for environmentally safe recycling.

Checking product received

- Upon receiving this product, inspect it for any shipping damage. Claims for damage, either apparent or concealed, should be filed immediately.
- Check the model number, electrical characteristics (power supply, voltage and frequency) and accessories to determine if they are correct.

The standard utilisation of the unit shall be explained in these instructions. Therefore, the utilisation of the unit other than those indicated in these instructions is not recommended.

Please contact your local agent, as the occasion arises.

Emerald's liability shall not cover defects arising from the alteration performed by a customer without Emerald's consent in a written form.

User guide

Safety summary	5
System description	5
Parts identification	6
Remote control switch	7
Display	7
Setting automatic swing louver	7
Automatic control	8
Filter cleaning	8
Troubleshooting	9

Important notice: Please read and keep this manual carefully before installing this product. Failure to do so may result in the product not working according to its design.

Operation manual

Safety Summary

DANGER

- Never pour water into the indoor or outdoor units. These products are equipped with electrical parts. If poured, it will cause a serious electrical shock.
- Do not touch or adjust safety devices inside the indoor or outdoor units. If these devices are touched or readjusted, it may cause a serious accident.
- Ensure the main power supply is switched OFF before accessing internal components.

WARNING

- Refrigerant leakage can cause difficulty with breathing due to insufficient air. If leakage occurs, turn OFF the main switch and contact your service contractor.
- Do not use any sprays such as insecticide, lacquer, hair spray or other flammable gases within approximately 1m (3.3ft.) from the system.
- If earth leakage breaker (ELB) or fuse is often activated, stop the system and contact your service contractor.

CAUTION

- The appliance is not to be used by children or person with reduced physical, sensory or mental capabilities, or lack of experience and knowledge, unless they have been given supervision or instruction concerning use of the appliance by a person responsible for their safety.
- Children should be supervised that they do not play with the appliance.
- The appliance should not be installed in the laundry.
- If the supply cord is damaged, it must be replaced by the manufacturer, its service agent or qualified persons in order to avoid a hazard.

NOTE

It is recommended that the room be ventilated every 3-4 hours.

System description

A maximum total capacity of 130% and a minimum total capacity of 50% can be chosen by combination of the indoor units. The heat pump air conditioner is designed to offer cooling, heating, dry and fan operations. These operation modes are controlled by the remote control switch (optional).

Operation

Identification of parts

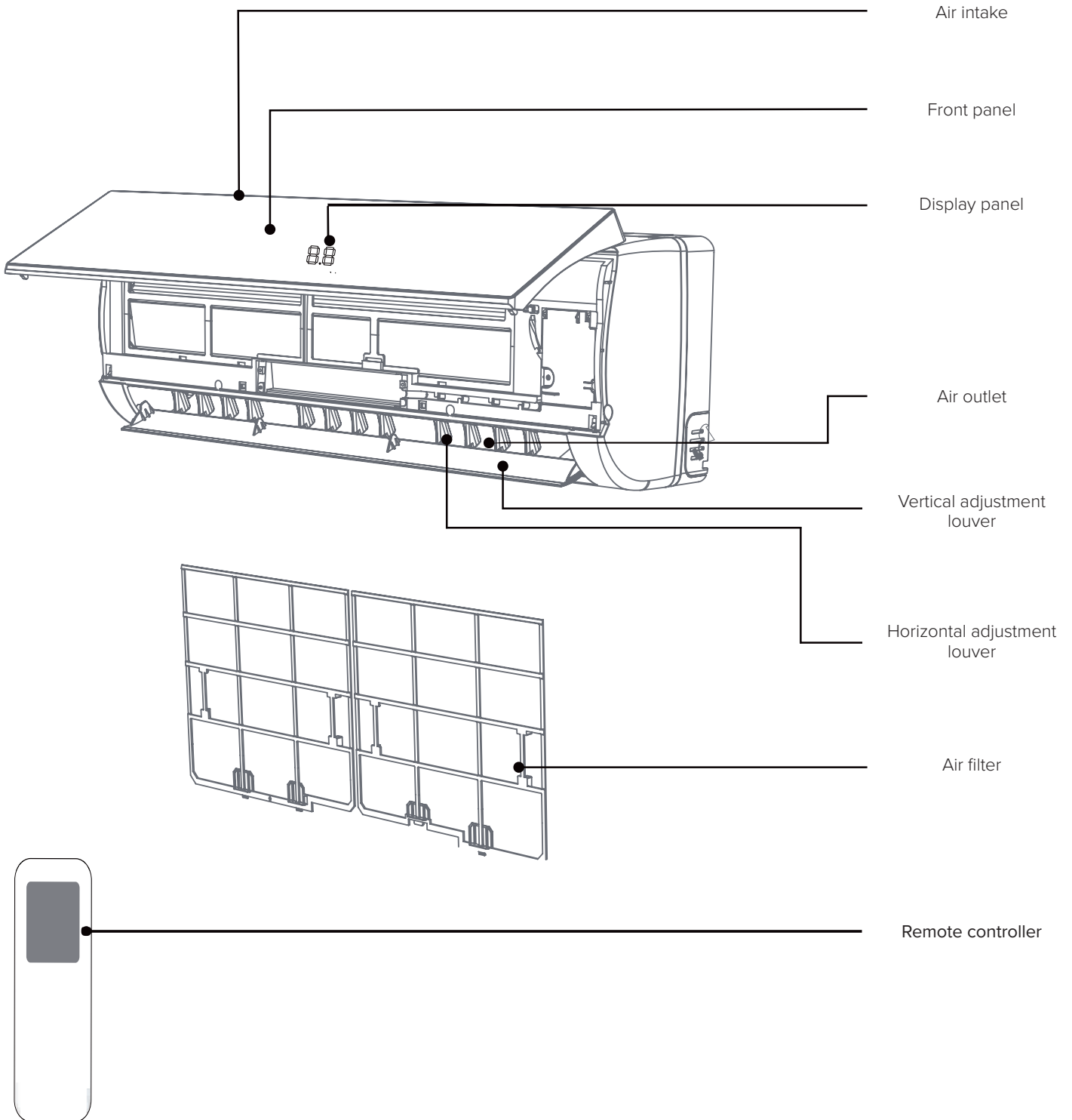

NOTE

Figures in the manual are only simple representation of the appliance. It may not comply with the appearance of the air conditioner you purchased.

Operation

Remote control switch

Refer to the control instruction manual for operation details.

Display

88 Temperature indicator

Display set temperature.
Displays 'FC' after 200 hours to remind you to clean the filter.
After filter cleaning press the filter reset button located on the indoor unit behind the front panel in order to reset the display.

Running indicator

Lights up when the AC is running.
Flashes during defrosting.

Timer indicator

Lights up during set time.

Sleep indicator

Lights up in sleep mode.

TD series

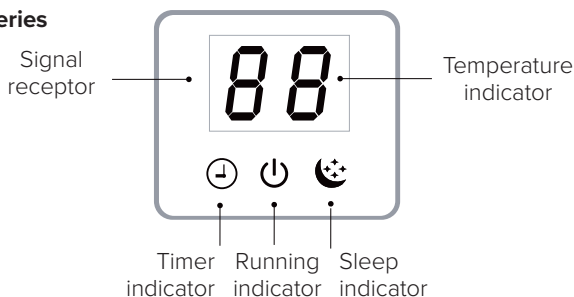

TE series

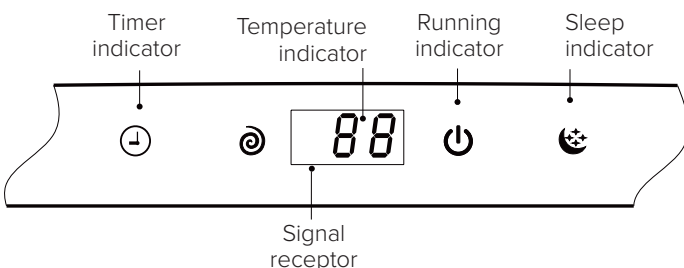

NOTE

To operate the room air conditioner, aim the remote controller to the signal receptor.

The remote controller will operate the air conditioner at a distance of up to 5m(16.5ft.) when pointing at signal receptor of indoor unit.

Signal light will illuminate for 10 seconds when the wireless remote is used..

Before operation

⚠ CAUTION

- Supply electrical power to the system for approximately 12 hours before startup after a long shutdown. Do not start the system immediately after power supply, it may cause compressor failure because the compressor is not heated well.
- Make sure that the outdoor unit is not covered with snow or ice. If covered, remove it by using hot water. (approximately 50°C)
- If the water temperature is higher than 50°C, it will cause damage to plastic parts.

When the system is started after a shutdown longer than approximately 3 months, it is recommended that the system be checked by your service contractor.

Turn OFF the main switch when the system is stopped for a long period of time. If the main switch is not turned OFF, electricity is consumed, because the oil heater is energized during compressor stopping.

Setting of automatic swing louver

When the 'louver' switch is pressed, the swing louver starts its operation.

When ' [j] ' is moving, it indicates the operation of the louver continuously. When the swinging operation of the louver is not required, press the 'louver' switch again. The louver is stopped at an angle indicated by the direction of this mark '[J]'.

NOTE

1. There exists a time lag between the actual angle of the louver and the liquid crystal indication.
2. When the "louver" switch is pressed, the louver will not stop immediately. The louver will move one extra swing at the next.
3. Discharge air angle is fixed at horizontal position during start-up of heating operation and defrosting operation. When the outlet air temperature reaches higher than approximately 30°C, swinging of louvers is started.
4. During the defrosting operation, fan stops running.

⚠ CAUTION

Do not turn the air louver by hand. If moved the louver mechanism will be damaged.

Operation

Automatic control

The system is equipped with the following functions:

• Three Minute Guard (Enforced Stoppage)

The compressor remains off for at least 3 minutes once it has stopped. If the system is started within approximately 3 minutes after it has stopped, the RUN indicator is activated. However, the cooling operation or the heating operation remains off and does not start until after 3 minutes has elapsed.

• Three Minute Guard (Enforced Operation)

If all indoor units of the system are ThermoOFF within approximately 3 minutes after compressor has started, compressor is operated during 3 minutes continuously. However, if all indoor units of the system are stopped by remote control switch, compressor is stopped.

• Oil Return Operation

If an indoor unit is stopped more than 2 hours continuously, this function is operated during a few minutes. It has this function to prevent to accumulate in the heat exchanger of stoppage indoor unit at cooling operation.

• Frost Prevention During Cooling Operation

When the indoor unit is operated at low discharge air temperature, the cooling operation may be changed to fan operation for a while to avoid frost formation on the indoor heat exchanger.

• Hot Start During Heating Operation

To avoid cold air blowing into the room, the fan speed is controlled from the slow position and the low position and then to the set position according to the discharge air temperature. At this time the louver is fixed horizontally.

• Slow Air Control During Defrosting Operation

When the outdoor unit is performing the automatic defrosting operation, the indoor fan is stopped and the louver is fixed horizontally.

• Cooling of Indoor Unit

When the heating operation is stopped, the indoor fan operation is maintained at the slow position for the maximum of 2 minutes to lower temperature of the inside unit.

• Automatic Defrosting Cycle

When the heating operation is stopped by pressing RUN/STOP switch, frosting on the outdoor unit is checked and the defrosting operation may be performed for the maximum of 10 minutes.

• Prevention of Overload Operation

When the outdoor temperature is high during heating operation, heating operation is stopped due to activation of the outdoor thermistor until the temperature becomes low.

Filter cleaning

⚠ CAUTION

Do not operate the system without the air filter to protect the indoor heat exchanger against being clogged.

Turn OFF the main power switch before taking out the filter. (The previous operation mode may appear.)

Taking Out the Filter

The indication, 'FILTER' is shown on the display of the remote control switch after approximately 1,200 hours of operation. Take out the air filter according to the following steps.

Step 1

Open the air inlet grille.

Step 2

Take out the air filter from the air inlet grille.

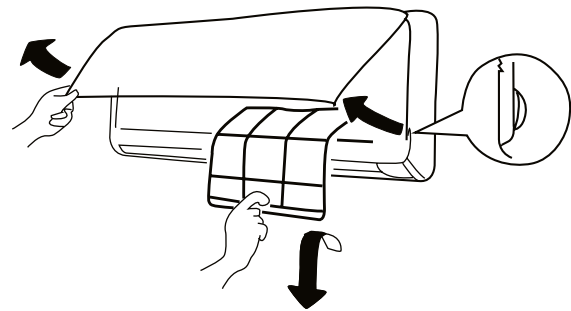

Clean the filter

Clean the air filter according to the following steps.

Step 1

Use a vacuum cleaner or let water flow onto the air filter for removing the dirt from the air filter.

⚠ CAUTION

Do not use hot water higher than approximately 40°C.

Step 2

Dry the air filter in the shade after shaking off water.

Reset of Filter Indication

After cleaning the air filter, press the 'RESET' button. The FILTER indication will disappear and the next filter cleaning time will be set.

Troubleshooting

CAUTION

- When overflow of drain water from the indoor unit occurs, stop the operation and contact your contractor.
- When you smell or see white smoke coming from the unit, turn OFF the main power supply and contact your contractor.

If problem persists

If the trouble still remains even after checking the following, contact your contractor and inform them of the following items.

1. Unit Model Name
2. Content of Trouble
3. Alarm Code No. on Liquid Crystal Display

No operation

Check whether the SET TEMP is set at the correct temperature.

Not cooling or heating properly

- Check for obstruction of air flow of the outside or inside units.
- Check if too much heat source exists in the room.
- Check if the air filter is clogged with dust.
- Check to see if the doors or windows are opened or not.
- Check if the temperature condition is not within the operation range.

The following is not unusual

- Smells from Indoor Unit
Odours may accumulate on the unit after extended use..
Clean the air filter and panels or allow a good ventilation.
- Sound from Deforming Parts
During system starting or stopping, an abrading sound might be heard. However, this is due to thermal deformation of plastic parts. It is not abnormal.
- Steam from Outdoor Heat Exchanger
During defrosting operation, ice on the outdoor heat exchanger is melted, resulting in steam.
- Dew on Air Panel
When the cooling operation continues for a long period of time under high humidity conditions (higher than 27°C(80°F)/ 80% R.H.), dew can form on the air panel.
- Refrigerant Flow Sound
While the system is being started or stopped, sound from the refrigerant flow may be heard.

Installation guide

Safety summary	11
<hr/>	
Transport and handling	
Transporting the indoor unit	11
Handling the indoor unit	11
<hr/>	
Indoor unit installation	
Factory supplied accessories	12
Initial check	12
Installation of mounting bracket onto wall	13
Mounting the indoor units	15
Removing flat panel	15
Install flat panel	16
<hr/>	
Refrigerant piping work	
Piping materials	16
Piping connection	16
<hr/>	
Drain piping	18
<hr/>	
Electrical wiring	19
General check	20
Electrical wiring connection	20
<hr/>	
Test run	22
<hr/>	
Safety and control device setting	22
<hr/>	
Field setting	
Field minimum wire sizes for power source	23
Setting of dip switches	23
Setting the filter indication interval	25
Indoor unit address	26
<hr/>	

Important notice: Please read and keep this manual carefully before installing this product. Failure to do so may result in the product not working according to its design.

Installation

Safety Summary

WARNING

- Do not perform installation work, refrigerant piping work, drain piping and electrical wiring connection without referring to the installation manual.
- Check that the ground wire is securely connected.
- Connect a fuse of specified capacity.
- Users shall not change power lines by themselves. They must be replaced by professional maintenance staff.

CAUTION

Do not install the indoor unit, outdoor unit, remote control switch and cable within approximately 3m (9.8ft.) from strong electromagnetic wave radiators such as medical equipment.

Necessary tools and instruments for installation

Handsaw	Spanner
Screwdriver	Charging cylinder
Vacuum pump	Gauge manifold
Refrigerant gas hose	Cutter for wires
Megohmmeter	Gas leak detector
Copper pipe bender	Leveler
Manual water pump	Clamper for solderless terminals
Pipe cutter	Hoist (for indoor unit)
Brazing kit	Ammeter
Hexagon wrench	Voltage meter

NOTE

About vacuum pump, gas hose, charging cylinder, gauge manifold, please use suitable equipments for R41 OA respectively. Do not mix other refrigerant.

Transport and handling

Transporting the indoor unit

Transport the product as close to the installation location as possible before unpacking.

CAUTION

Do not put any material on the product.

Handling the indoor unit

WARNING

Do not put any unnecessary material into the indoor unit and check to ensure that none exists in the indoor unit before the installation and test run. Otherwise, a fire or failure, etc. may occur.

CAUTION

Be careful not to damage on insulation materials of unit's surface when lifting

Installation

Indoor unit installation

⚠ DANGER

Do not install the indoor unit in a flammable environment to avoid fire or an explosion.

⚠ WARNING

- Check to ensure the wall structure is strong enough to support the indoor unit to avoid it falling.
- Do not install the indoor unit outdoors. If installed outdoors and electric hazard will occur.
- If earth leakage breaker (ELB) or fuse is often activated, stop the system and contact your service contractor.







It is recommended the indoor units be installed higher than 2.5m (8.2ft.) from floor level.

Factory supplied accessories

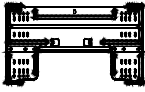
Ensure the following accessories are included with the indoor unit.

NOTE

If any of these accessories are not packed with the unit please contact your supplier.

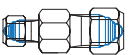
Accessory	Quantity	Purpose
Mounting bracket 	1	For mounting indoor unit
Wireless remote control switch 	1	To control the indoor unit
Screw 	6	For mounting bracket
Screw cover 	1 (28-36) 3 (45-84)	Cover screw hole
Thermal insulation pipe 	1	For refrigerant pipe
Plug 	6	For mounting bracket
Refrigerant pipe connection 	2	For refrigerant pipe
Adapter 	1 (28-36) 2 (56-84)	For Piping Connection

Initial check

- Install the indoor unit with a proper clearance around it for operation and maintenance working space,

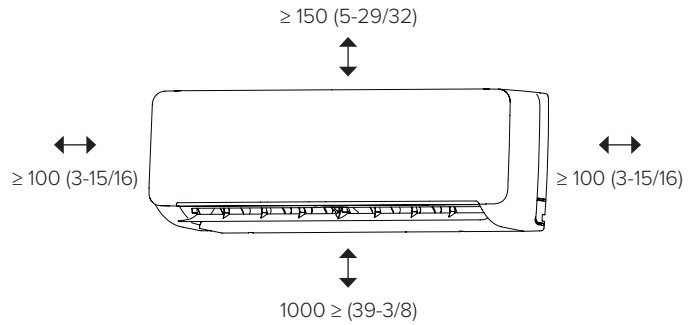

Operation and maintenance space. Unit: mm (in.)

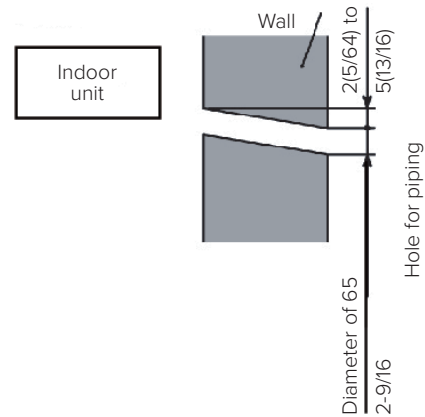

Hole for piping in the wall. Unit: mm (in.)

- Consider the air distribution from the indoor unit to the space of the room, and select a suitable location so that uniform air temperature in the room can be obtained.
- Avoid obstacles which may hamper the air intake or the air discharge flow.
- Do not install the indoor unit in a machine shop or kitchen where vapour from oil or its mist flows to the indoor unit. The oil will deposit on the heat exchanger, thereby reducing the indoor unit performance, and may deform and in the worst case, break the plastic parts of the indoor unit.
- Pay attention to the following points when the indoor unit is installed in a hospital or other facilities where there are electronic waves from medical equipment.
 - (A) Do not install the indoor unit where the electromagnetic wave is directly radiated to the electrical box, remote control cable or remote control switch
 - (B) Install the indoor unit and components as far as practical or at least 3m(9.8ft.) from the electromagnetic wave radiator.
 - (C) Prepare a steel box and install the remote control switch in it. Prepare a steel conduit tube and wire the remote control cable in it. Then, connect the ground wire with the box and the tube.
 - (D) Install a noise filter when the power supply emits harmful noises.
- To avoid any corrosive action to the heat exchangers, do not install the indoor unit in an acid or alkaline environment.

Installation

Installation of mounting bracket onto wall

When the mounting bracket is directly attached to a wood or concrete wall, check to ensure of 2000N(0.45kip).

Mounting on a concrete or concrete block wall: Attach the mounting bracket to the wall with anchor bolts as shown.

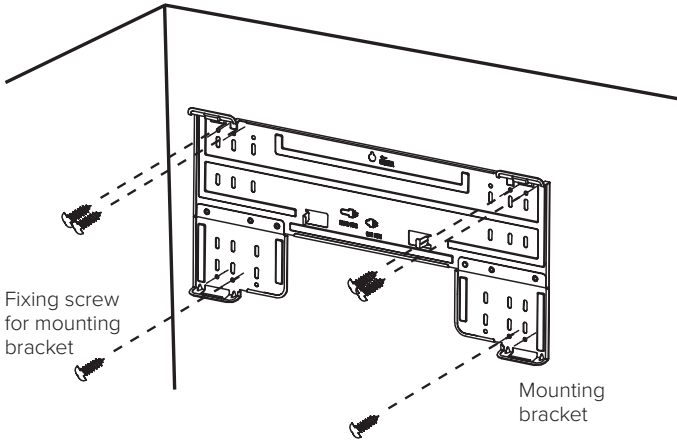

Mounting on concrete or concrete block wall

NOTE

The mounting bracket should be installed so that the side of drain piping connected is slightly (about 3mm(1/8in.)) lower than the other side, in order to avoid the incorrect position of the drain discharge.

(Drain piping connection can be performed both right side and left side of the unit.)

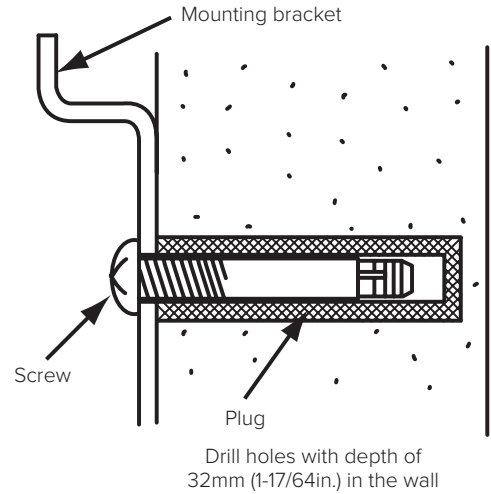

NOTE

As shown above, the six holes matched with tapping screw on the mounting plate must be used to fix the mounting plate. The others are prepared.

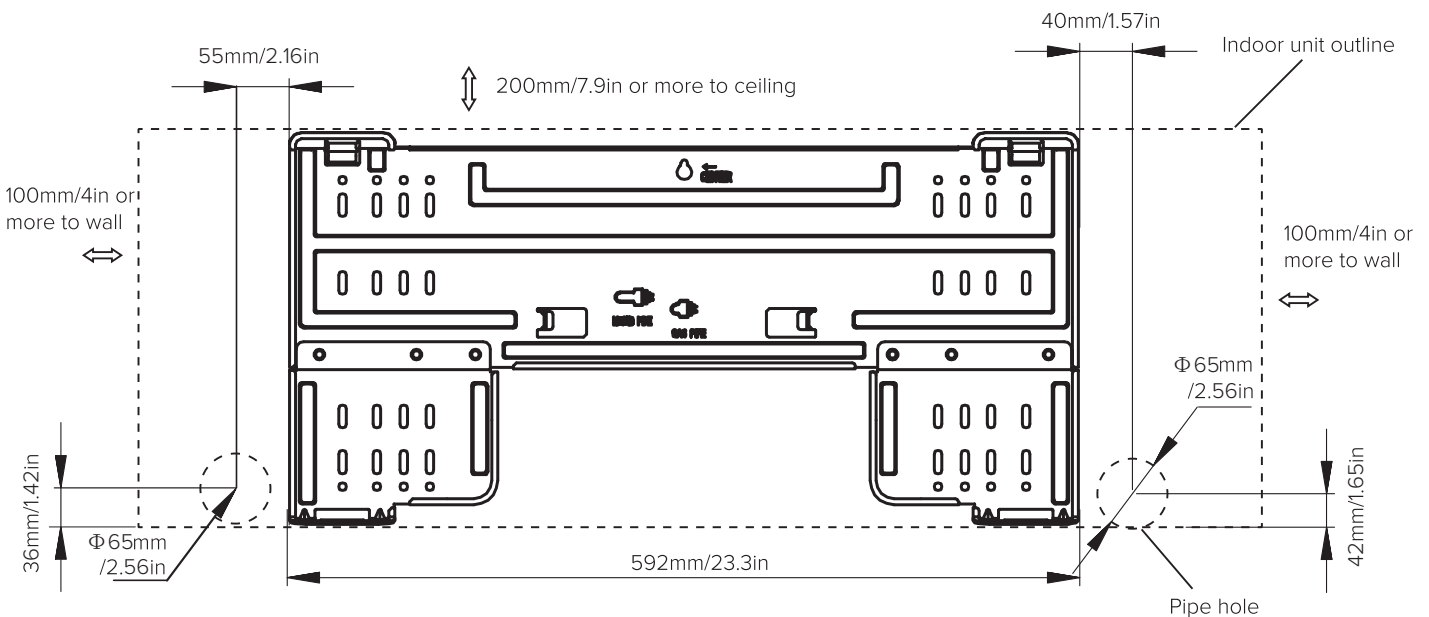

ACV28~36W Mounting bracket

Installation

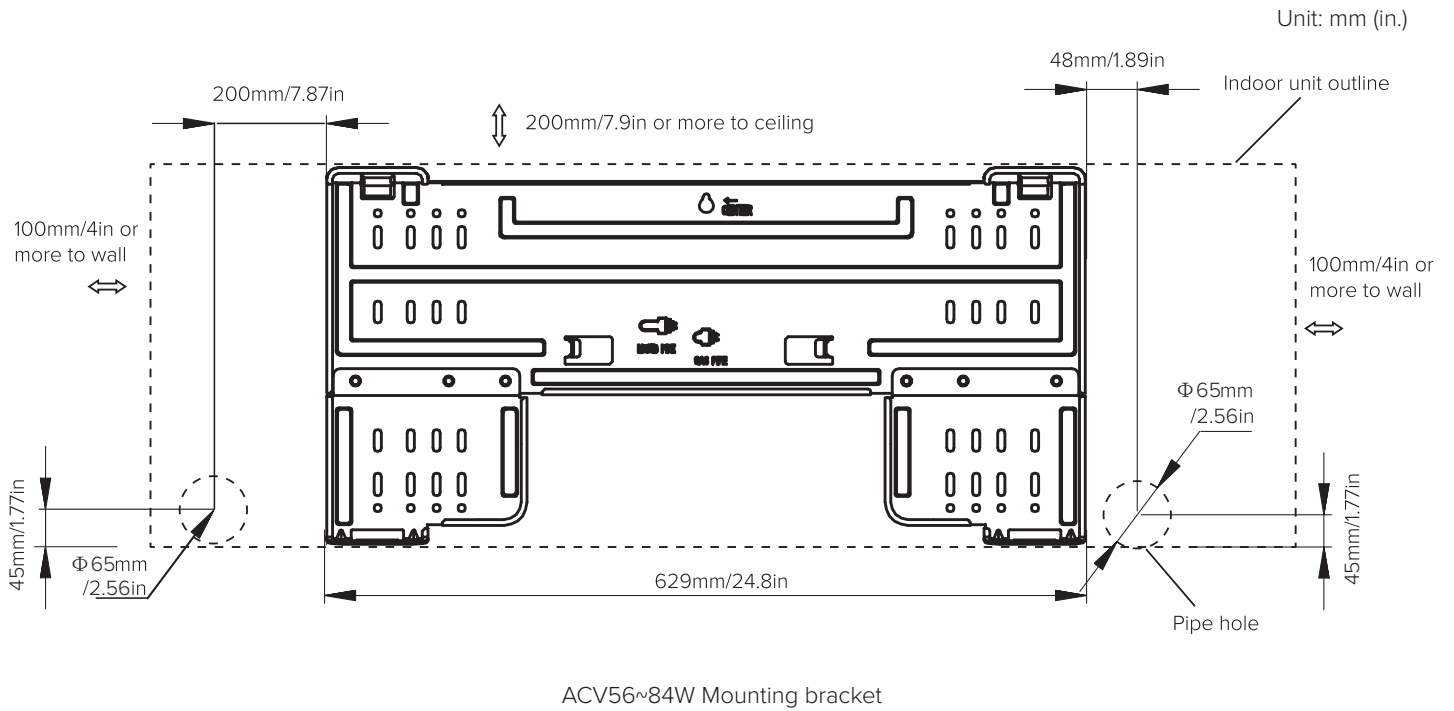
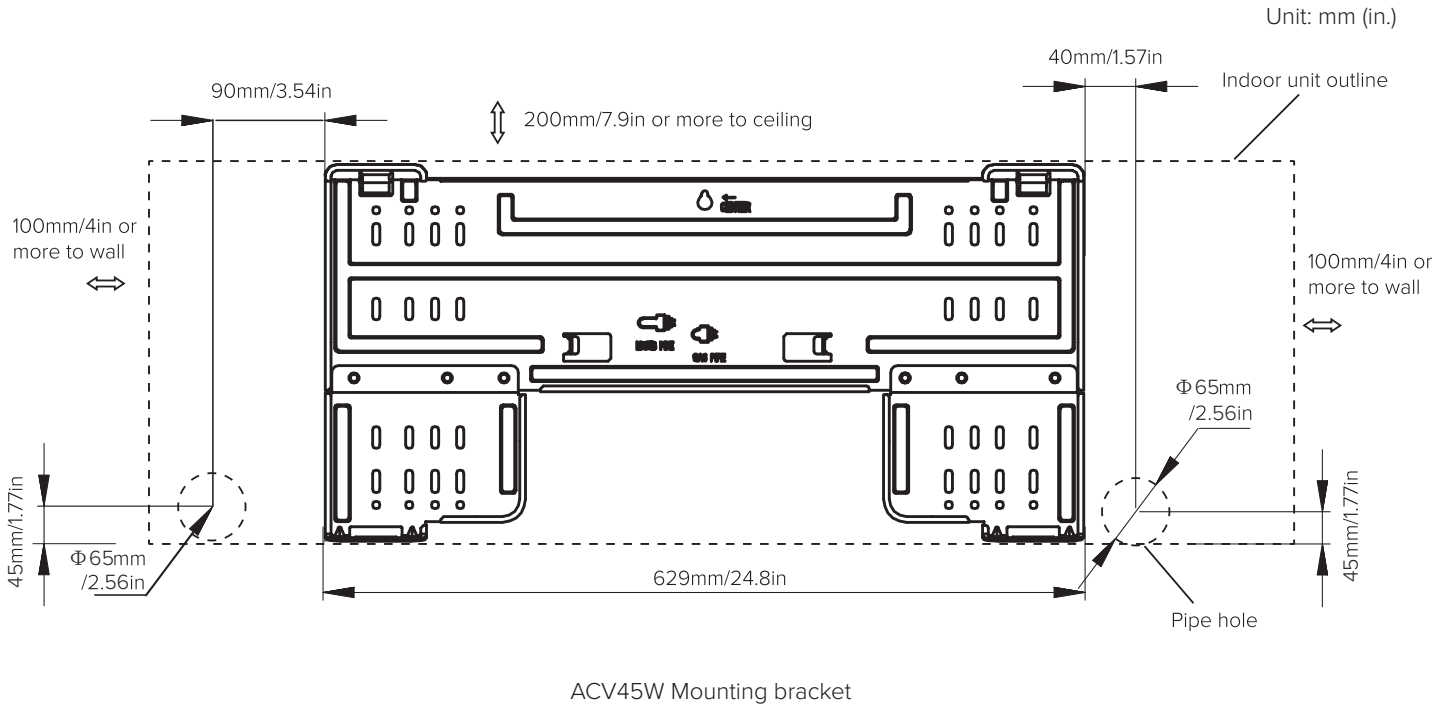

Installation

Mounting the indoor units

Hook the indoor unit to the mounting bracket, keeping the indoor unit upright.

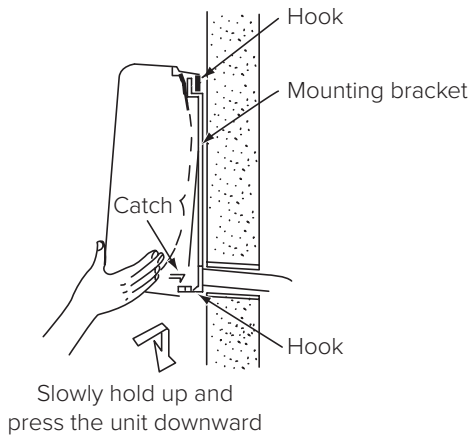

Mounting indoor units

⚠ CAUTION

Ensure the unit is securely attached to the bracket. If not, it may drop from the bracket, resulting in a serious accident.

1. The side of the drain pipe is downward-sloping 2 degrees or 3 degrees in the process of the unit installation.
2. Check the drainage of the drain pan through water overflow test.

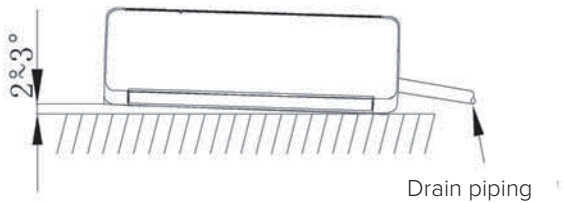

Angle of indoor units

Removing flat panel

In order to connect the refrigerant piping, wiring and to check drain water flow, removing the flat panel is needed. Perform these work according to the following instructions. Careful not to scratch the resin components.

1. Hold both sides of the flat panel and open it, and pull the right arm toward the inner side. Slightly close the flat panel and pull it, then remove the flat panel.

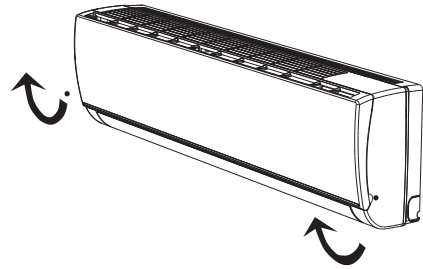

Flat panel

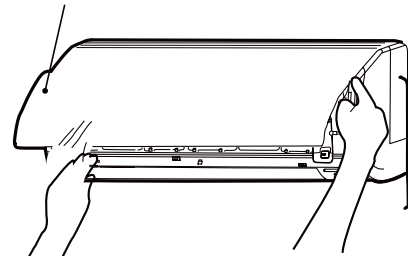

2. Pay attention to the junction of grille from each side, to prevent breaking off.

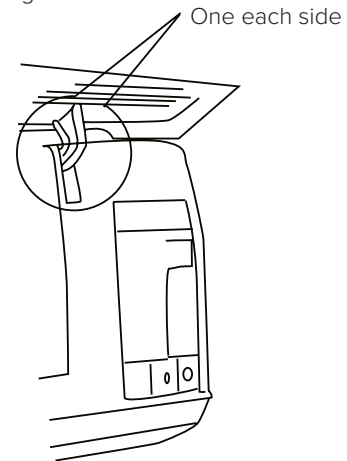

⚠ CAUTION

When removing flat panel, do not apply strong forces by hitting, etc. It may break the unit body.

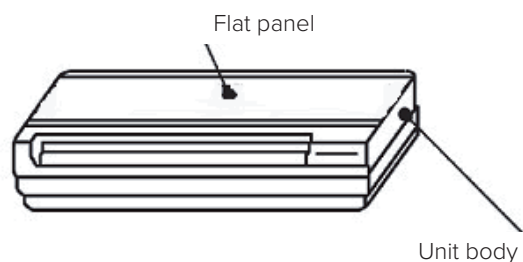

Installation

Install flat panel

1. Press flat panel down, make the two joints of the flat panel tightly fasten.

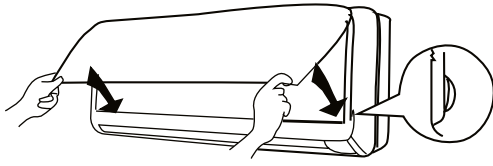

2. There are four stoppers inside of the flat panel. Check to ensure that there is no gap between flat panel and unit body.

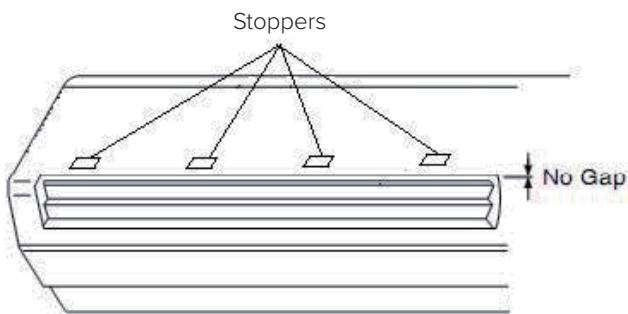

CAUTION

Any gap will lead to leak or frost.

3. Put screws cover into the screw hole in the air outlet.

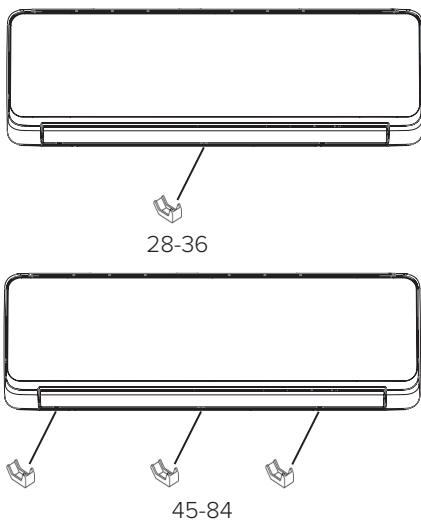

Refrigerant piping work

DANGER

Use refrigerant R410A in the refrigerant cycle. Do not charge oxygen, acetylene or other flammable and poisonous gases into the refrigerant cycle when performing a leakage test or an air-tight test. These types of gases are extremely dangerous and can cause an explosion. It is recommended that compressed air, nitrogen or refrigerant be used for these types of tests.

Piping materials

1. Prepare locally-supplied copper pipes.
2. Select the piping size from the following table.

Model	Gas pipe	Liquid pipe
28~36	φ9.53(3/8)	φ6.35(1/4)
45	φ12.7(1/2)	φ6.35(1/4)
56~84	φ15.88(5/8)	φ9.53(3/8)

3. Select clean copper pipes making sure there is no dust and moisture inside the tubes. Before connecting pipes, blow the inside of the pipes with nitrogen or dry air to remove any dust or foreign materials.

Piping connection

1. Position of piping connection is shown.
2. Piping direction for the indoor unit: Three directions of piping connection to the indoor unit can be performed; to the rear side, the right side and the left side of the unit respectively. Therefore, most appropriate piping for a room can be selected.

Right side piping

Take off the small cover from right side.

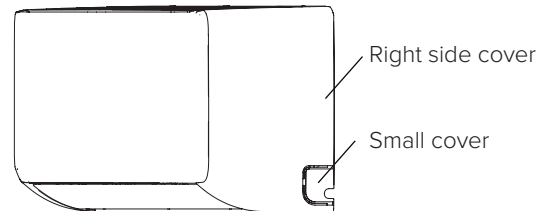

Left side piping

Take off the small cover from right side.

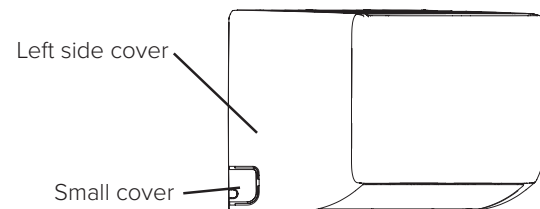

Installation

- Rear side piping
Bend the pipe directly toward the rear.

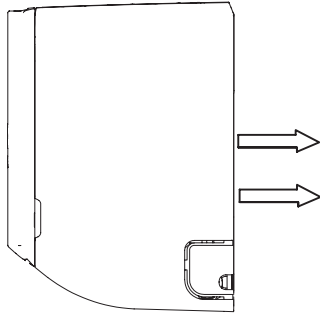

- Bend the gas pipe at the flexible pipe part.

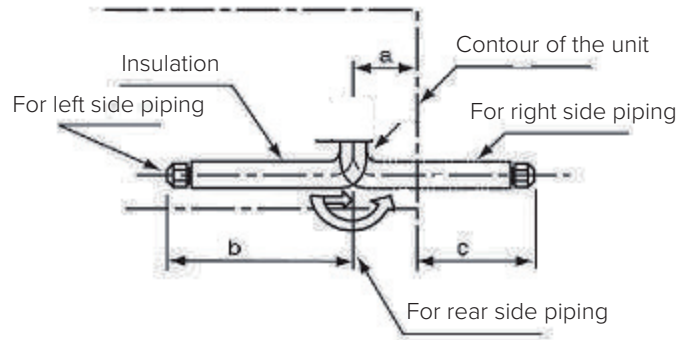

Gas pipe

Unit: mm (in.)

Model	a	b	c	d
28~36	101 (3-31/32)	390 (15-23/64)	289 (11-3/8)	15R (19/32R)
45	78 (2-5/64)	396 (15-19/32)	318 (12-33/64)	20R (25/32R)
56~84	76 (3)	431 (16-31/32)	355 (13-31/32)	25R (63/64R)

CAUTION

- Cap the end of the pipe when the pipe is to be inserted through a hole.
- Do not put pipes on the ground directly without a cap or vinyl tape at the end of the pipe.

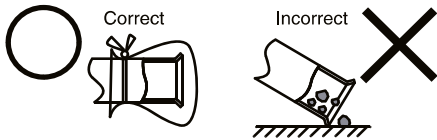

- When bending the pipes, firmly fix the pipe at the heat exchanger side.

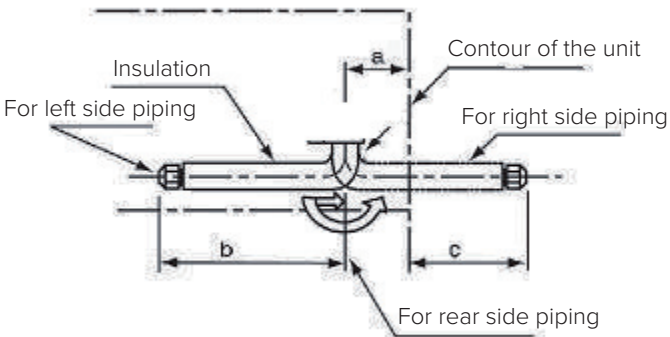

Liquid pipe

Unit: mm (in.)

Model	a	b	c	d
28~36	86 (3-25/64)	456 (3-25/64)	370 (14-9/16)	456 (3-25/64)
45	64 (2-33/64)	437 (17-13/64)	373 (14-11/16)	(3-25/64)
56~84	60 (2-23/64)	464 (18-17/64)	404 (15-29/32)	456 (3-25/64)

- When tightening the flare nut, use two spanners as shown.

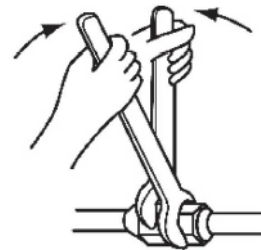

Pipe Diameter	Torque ((N·m)/ft·lbs)
φ6.35(1/4)	20 (14.8)
φ9.53(3/8)	40 (29.5)
φ12.7(1/2)	60 (44.3)
φ15.88(5/8)	80 (59)

Tightening work of flare nut

Installation

4. Insulate the refrigerant pipes as shown.

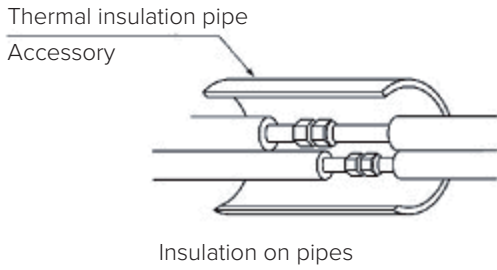

5. Evacuation and refrigerant charging procedures should be performed according to "Outdoor Unit User Manual".

⚠ CAUTION

An excess or a shortage of refrigerant is the main cause of trouble to the units. Charge the correct refrigerant quantity.

6. Put screws cover into the screw hole in the air outlet.

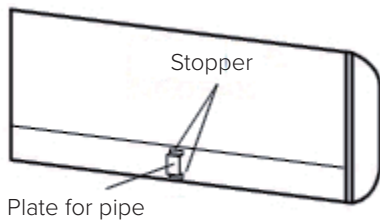

Drain piping

1. The standard direction of drain piping connection is right side as viewed from the discharge grilles. However, it can be performed from the left side or rear side.

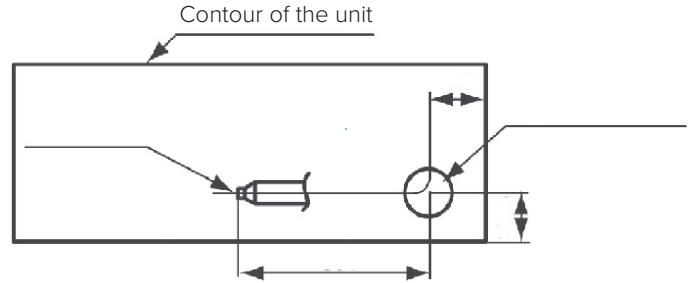

Unit: mm (in.)

Model	a	b
28~36	140 (5-33/64)	590 (23-15/64)
45	168 (6-39/64)	600 (23-5/8)
56~84	195 (7-43/64)	600 (23-5/8)

Direction of drain piping

2. When the left-side drain pipe connection is performed, remove the drain plug of left-side, and then attach this plug to the right-side in order to change drain piping connection from right-side to left-side.

(A) Draw out the drain plug and drain pipe.

Remove the fixing screw for right-side drain pipe and draw out the drain pipe from drain boss.

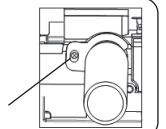

Use pliers to pull out the drain plug for left-side. (This is an easier way to remove the drain cap).



(B) Insert the drain plug and drain pipe

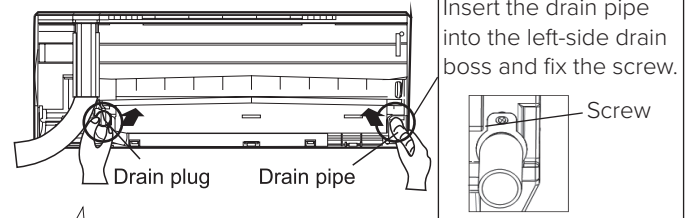

Insert the drain pipe into the left-side drain boss and fix the screw.

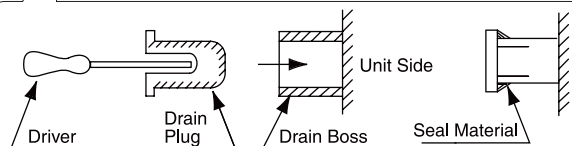

• Insert the drain plug into the right-side drain boss and seal the jointed part with water-proof chloride sealing material.

Installation

⚠ CAUTION

Insufficient insertion may result in water leakage.

3. Provide a vinyl chloride pipe, VP20.
4. Connect a drain piping as shown.
Use adhesive tape for connecting the drain pipe.

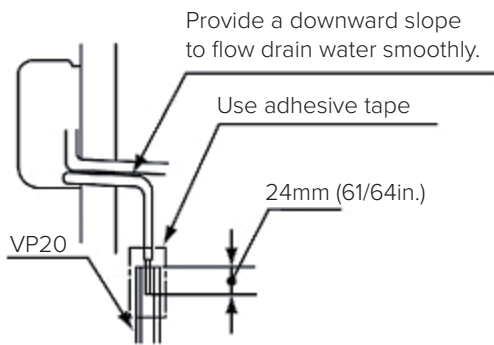

5. Pour water into the drain pan to confirm proper drainage.

⚠ CAUTION

- Do not connect the drain pipes with sanitary or sewage or any other drainage pipe.
- When installing the pipe, do not tie the drain pipe and refrigerant pipe together.
- Pay attention to the thickness of the insulation when the left side piping is performed. If it is too thick, piping can not be installed in the unit.

⚠ CAUTION

1. Do not create an upper-slope or rise for the drain piping, since drain water can flow back to the unit and leakage to the room will occur when the unit operation is stopped.
2. When the common drain piping is connected with other indoor units, the connected position of each indoor unit must be higher than the common piping. The pipe size of the common drain pipe must be large enough according to the unit size and number of units.

Electrical wiring

⚠ WARNING

- Turn OFF the main power switches to the indoor unit and outdoor unit before electrical wiring or periodical check, and wait for at least 10 minutes.
- Check to ensure the indoor and outdoor fans have stopped before electrical wiring or periodical check.
- Protect the wires, drain pipes, electrical parts, etc. from rats or other small animals. If not protected, rats may gnaw at unprotected parts, which may lead to a fire.
- Avoid the contact of wires with the refrigerant piping, sheet metal edges and electrical components in unit. Otherwise, the wires may get damaged or even cause a fire.
- Use ELB (earth leakage breaker) with medium sensing rate (ELB with action time being equal to 0.1 seconds or less). Failing to do so may result in electric shock or a fire.
- The wires must be firmly secured. External force applied to terminals may cause a fire.
- It is forbidden to connect a plurality of power lines into one power terminal block. At the indoor unit side of air conditioner, power wiring can be extended through a power distribution box. Be sure to calculate the wiring capacity carefully, since excessively low wiring capacity may frequently cause fire.
- Ensure all points have been checked thoroughly.

⚠ CAUTION

- Tighten screws according to the following torque.

N·m(ft·lbs)

M3.5:	1.2(0.89)
M4:	1.0~1.3(0.7~1.0)
M5:	2.0~2.4(1.5~1.8)
M6:	4.0~5.0(3.0~3.7)
M8:	9.0~11.0(6.6~8.1)
M10:	18.0~23.0(13.3~17.0)

- Wrap the accessory packing around the wires, and plug the wiring connection hole with the seal material to protect the product from any condensate water or insects.
- Tightly secure the wires with the cord clamp inside the indoor unit.
- Secure the cable of the remote control switch using the cord clamp inside the electrical box.

Installation

General check

1. Make sure that the field-supplied electrical components (main power switches, circuit breakers, wires, conduit connectors and wire terminals) have been properly selected according to the electrical data given in "Technical Catalog I". Make sure that the components comply with National Electrical Code (NEC).
 2. Use shielded twist pair cable for transmission wiring between outdoor unit and indoor unit, remote controller wiring between indoor units and remote control switch.
 3. Check to ensure that the power supply voltage is within $\pm 10\%$ of the rated voltage.
 4. Check the capacity of the electrical wires. If the power source capacity is too low, the system cannot be started due to the voltage drop.
 5. Check to ensure that the earth wire is connected.
 6. Power Source Main Switch. Install a multi-pole main switch with a space of 3.5mm(9/64in.) or more between each phase.
1. Connect the wires of an optional remote control switch to A, B terminals of the terminal board inside the electrical box through the connecting hole in the cabinet.
 2. Connect the wires between the indoor unit and the outdoor unit to 1,2 terminals of the terminal board inside the electrical box through the connecting hole in the cabinet.
 3. Connect power supply wires to L, N and connect earth wire to the earth. Please connect to the power with a ELB.
 4. Check to ensure that the terminal specification is applied to the screw (M3.5 for power supply and operating line) of the terminal box.
 5. Fix all the wires securely with cord clamp.

Electrical wiring connection

The electrical wiring connection for the indoor unit is shown

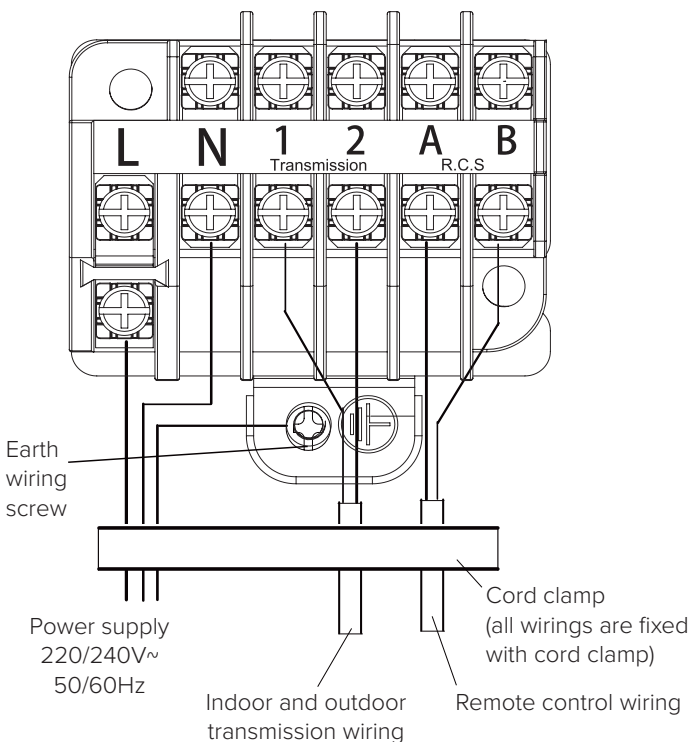

Installation

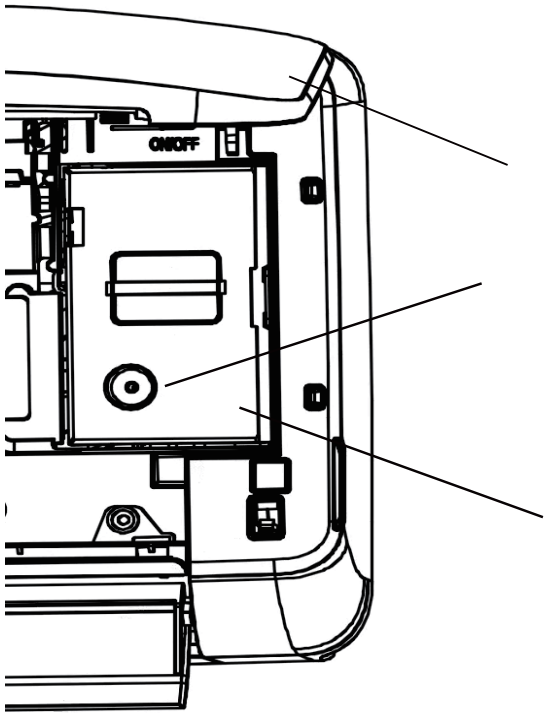

Open the flat panel

Remove the fixing screw
for the electrical box cover

Electrical box cover

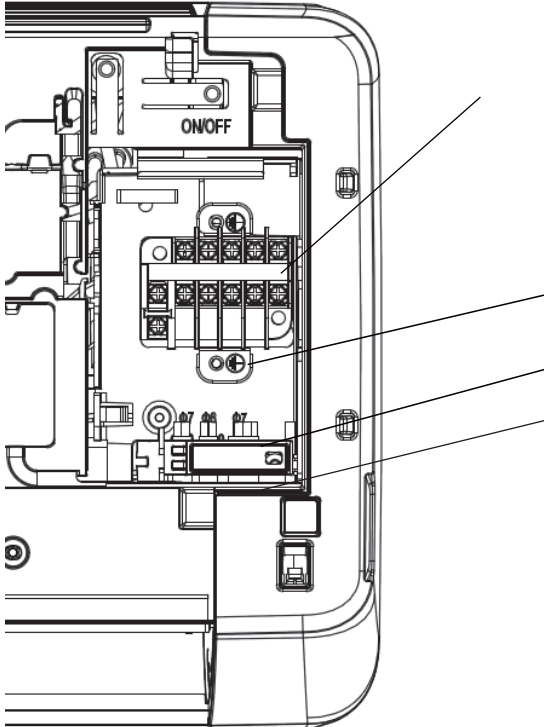
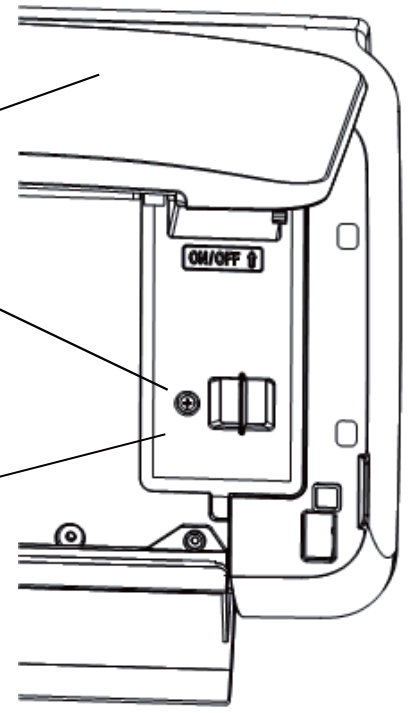

TB1 for Power Supply (L N)
and Transmission wiring (1 2)
and Remote control switch (A B)

TP (terminal plate)
for Earth wire

Cord clamp

Pass the wires
through the hole in
the cabinet to the rear side

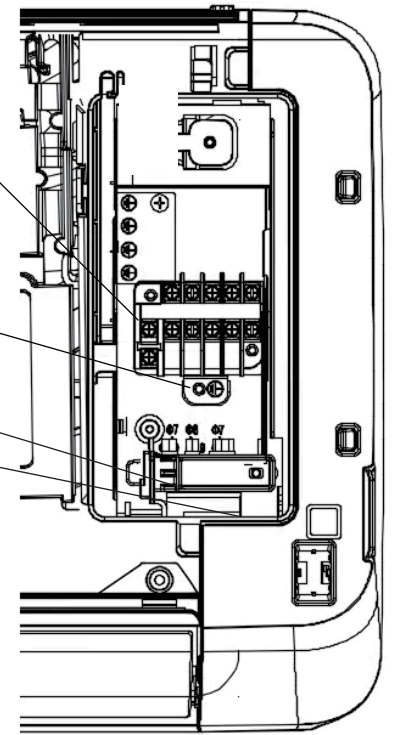

Installation

⚠ CAUTION

- ELB must be connected to the power circuit. If not, it may pose a danger.
- Apply the specified screw for terminal board and fasten the screw firmly.

NOTE

Wired Remote Control Switch and Wireless Remote Control Switch can not be used simultaneously. If Wired Remote Control Switch is connected, disconnect the wire of signal receptor in the electrical box as shown.

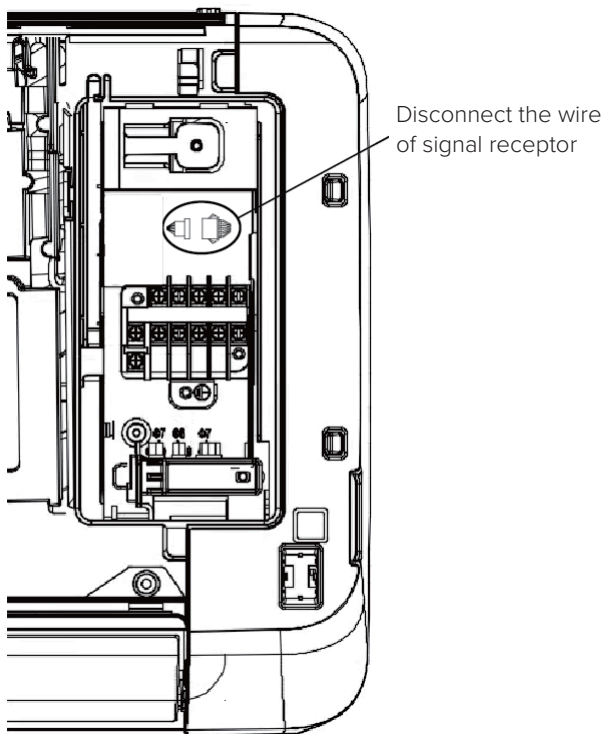

Connection description for signal receptor

Test run

Test run should be should be performed according to "Outdoor Unit User Manual".

⚠ WARNING

- Do not operate the system until all the check points have been cleared.
 - (A) Check to ensure that the electrical resistance is more than 1 megohm, by measuring the resistance between ground and the terminal of the electrical parts. If not, do not operate the system until the electrical leakage is found and repaired.
 - (B) Check to ensure that the stop valves of the outdoor unit are fully opened, and then start the system.
 - (C) Check to ensure that the switch on the main power source has been ON for more than 12 hours, to warm the compressor oil by the crankcase heater.
- Pay attention to the following items while the system is running.
 - (A) Do not touch any of the parts by hand at the discharge gas side, since the compressor chamber and the pipes at the discharge side are heated higher than 90°C
 - (B) DO NOT PUSH THE BUTTON OF THE MAGNETIC SWITCH(ES). It will cause a serious accident.

Safety and control device setting

Indoor unit

Model		28~84	
For control circuit Fuse capacity		A	5
Freeze protection Thermostat	cut-out	°C	0
	cut-in	°C	14

Installation

Field Setting

Field minimum wire sizes for power source

⚠ WARNING

- Use an ELB (Electric Leakage Breaker). If not used, it will cause an electric shock or a fire.

Model	Power source	Rated current	Power source cable size *1	Transmitting cable size *1
28	220~240V 50/60Hz	0.36A	1.5mm ²	0.75mm ²
36		0.43A		
45		0.45A		
56		0.45A		
71		0.75A		
84		0.81A		
Total current (A)		Wire (mm ²)		*1 DO NOT connect wires in series when the current exceeds 63A
1≤6		2.5		
6<1≤10		2.5		
10<1≤16		2.5		
16<1≤25		4		
25<1≤32		6		
32<1≤40		10		
40<1≤63		16		
63<1		*1		

NOTE

- Field wiring shall be in conformity to local laws and regulations, and all wiring operations must be performed by qualified professionals.
- Refer to relevant standards for above-noted power cord size.
- Where power cord is connected through junction box, be sure to determine the total current and choose wires based on the table below.
- As a minimum, the chosen power cord shall be compliant with requirements on neoprene sheathed wire #57 as stated in IEC 60245-1, while the power cord shall be made from copper conductor.
- The wiring specifications for weak-current communication circuit shall not be lower than that for RW(S)P shielded wires or equivalent, and the shielding layer shall be grounded.

- A switch that can ensure all-pole disconnection shall be installed between power supply and air conditioning unit in such a manner that the contact spacing shall not be less than 3mm.
- Once the power cord is damaged, the dealer or the professionals from designated maintenance department must be contacted in a timely manner for repair and replacement.
- For the installation of power cord, the ground wire must be longer than the current-carrying conductor.

Setting of dip switches

- DIP switch must be set with power sources of the indoor and outdoor units in OFF state. Otherwise, the settings are invalid.
- The DIP switches are located as shown.

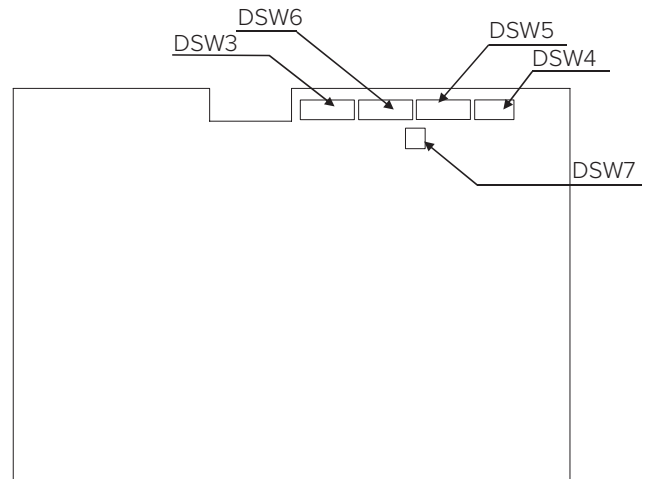

- 5 DIP switches are arranged on the PCB of indoor unit, and must be set based on the following instructions before test run. The system shall not be started before the completion of DIP switch setup.

- (a) Address of indoor units (DSW6): All indoor units must be numbered in sequence based on the diagram below. Outdoor units must be numbered from "O".

	DSW6 (Setting 0~63)	Ex.) Set address No. 16
Setting method	 Note: 8421 coding method	 No.5 is ON

- (b) Refrigeration system cycle No. (DSW5) is required to be set. All are set to OFF before shipment.

	DSW5 (Setting 0~63)	Ex.) Set address No. 16
Setting method 2	 Note: 8421 coding method	 No.5 is ON

Installation

4. Fuse Recover (DSW7)

No setting is required.

Setting position before shipment is at OFF.

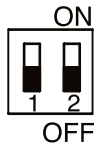

Once strong current is accidentally connected to Terminals 1 and 2 of TB, the PCB fuse will be blown. In such a case, it's essential to correct the wiring and then to set switch No. 1 to ON position.

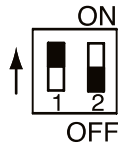

NOTE

- The "■" mark indicates position of dip switches. Figures show setting before shipment.

⚠ CAUTION

Before setting dip switches, firstly turn OFF power source and set the position of the dip switches. If the switches are set without turning OFF the power source, the switches can not function.

Decimal No	8421 code					
	1	2	3	4	5	6
0	○	○	○	○	○	○
1	●	○	○	○	○	○
2	○	●	○	○	○	○
3	●	●	○	○	○	○
4	○	○	●	○	○	○
5	●	○	●	○	○	○
6	○	●	●	○	○	○
7	●	●	●	○	○	○
8	○	○	○	●	○	○
9	●	○	○	●	○	○
10	○	●	○	●	○	○
11	●	●	○	●	○	○
12	○	○	●	●	○	○
13	●	○	●	●	○	○
14	○	●	●	●	○	○
15	●	●	●	●	○	○
16	○	○	○	○	●	○
17	●	○	○	○	●	○
18	○	●	○	○	●	○
19	●	●	○	○	●	○

20	○	○	●	○	●	○
21	●	○	●	○	●	○
22	○	●	●	○	●	○
23	●	●	●	○	●	○
24	○	○	○	●	●	○
25	●	○	○	●	●	○
26	○	●	○	●	●	○
27	●	●	○	●	●	○
28	○	○	●	●	●	○
29	●	○	●	●	●	○
30	○	●	●	●	●	○
31	●	●	●	●	●	○
32	○	○	○	○	○	●
33	●	○	○	○	○	●
34	○	●	○	○	○	●
35	●	●	○	○	○	●
36	○	○	●	○	○	●
37	●	○	●	○	○	●
38	○	●	●	○	○	●
39	●	●	●	○	○	●
40	○	○	○	●	○	●
41	●	○	○	●	○	●
42	○	●	○	●	○	●
43	●	●	○	●	○	●
44	○	○	●	●	○	●
45	●	○	●	●	○	●
46	○	●	●	●	○	●
47	●	●	●	●	○	●
48	○	○	○	○	●	●
49	●	○	○	○	●	●
50	○	●	○	○	●	●
51	●	●	○	○	●	●
52	○	○	●	○	●	●
53	●	○	●	○	●	●
54	○	●	●	○	●	●
55	●	●	●	○	●	●
56	○	○	○	●	●	●
57	●	○	○	●	●	●
58	○	●	○	●	●	●
59	●	●	○	●	●	●
60	○	○	●	●	●	●
61	●	○	●	●	●	●
62	○	●	●	●	●	●
63	●	●	●	●	●	●

Installation

Setting the filter indication interval

The FILTER indication interval on the remote control switch can be set at every 100, 1,200 or 2,500 hours (factory setting: 1200 hours). If 100, 1,200 or 2,500 hours' interval is required, follow the instructions below.

1. Press and hold (menu) and (return) simultaneously for at least 3 seconds during the normal mode (when unit is not operated). The test run menu will be displayed.
2. Select 'Optional Setting' from the test run menu pressing .
3. Select the indoor unit by pressing $\wedge \vee < >$ and press . (This screen is NOT displayed when the number of indoor unit connected with the remote control switch is 1 (one). In this case, (4) will be displayed.)
4. Press $\wedge \vee$ and select the item.
5. Press $< >$ and change the setting.

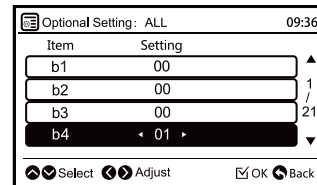
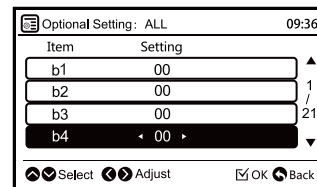
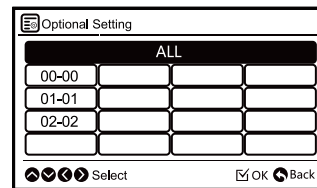
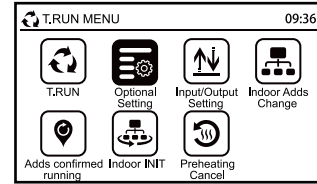

FILTER indication interval				
Approx. 100hr	Approx. 1,200hr	Approx. 1,200hr	Approx. 2,500hr	No indication
b4 01	b4 00(*)	b4 02	b4 03	b4 04

(*) Standard

6. Press so that the confirmation screen will be displayed.
7. Select 'Yes' and press . The test run menu will be displayed after the setting is confirmed. If 'NO' is pressed, the screen will return to (4).
8. Press (return) on the test run menu to return to the normal mode.

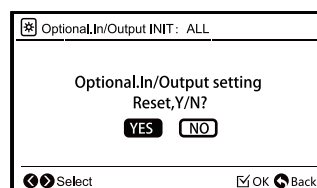





To set other units, press (return) at (4) (5) so that the screen will return to (3). (If the number of indoor unit connected with the remote control switch is 1 (one), the screen will return to (1).)

Installation

Indoor unit address

- Indoor unit address change.

- Press and hold  (menu) and  (return) simultaneously for at least 3 seconds during the normal mode (when unit is not operated). The test run menu will be displayed.
- Select 'Indoor Adds Change' from the test run menu pressing $\wedge \vee < >$ and .
- Select the indoor unit by pressing $\wedge \vee < >$ and press .

*Indoor units which are not supporting " Indoor Adds Change "function can not be selected.

- Determine the new indoor unit address. Press $\wedge \vee < >$ to switch the refrigerant cycle number and address in range of 00-63.
To display confirmation screen press .



* 'R.N No.99' is used temporarily address only when all the cycle numbers and unit numbers are in use (occupied).

If 'R.N No.99' is used temporarily, the address must be changed within the standard range of 00-63.

- The confirmation screen will be displayed. Select 'Yes' and press  to started address change process. Result will be displayed in seconds. If 'No' is pressed, the screen will go to (6).

*When the process successfully completes 'Adds Change Ended' will be displayed.

Otherwise the process has been failed. Check the setting and contents again.

- To change the address for another indoor unit, select 'Indoor Units Select' and press  the screen will return to (3). To finish this function select 'Adds Change Done' and press .

*If 'Indoor Adds Change' is successfully completed, connection check will be started automatically.

- Turn OFF the power supply of the indoor units for 3-5 minutes. Wait until the remote control switches display turn off, and turn ON the power supply of indoor units again.

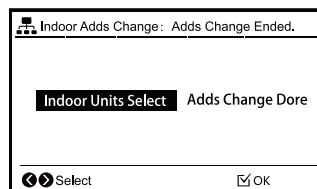
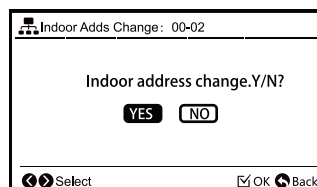
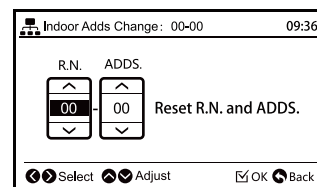
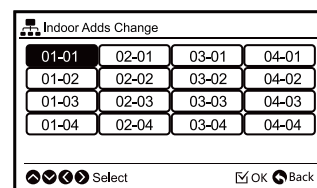
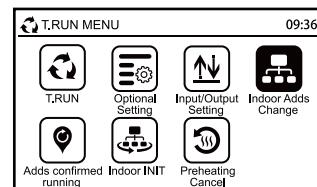

NOTE

'Indoor Adds Change' is not available when the control of 2 remote control switches (main and sub) are used.

Do not operate from the central controlling devices while 'Indoor Adds Change' is performed by the remote control switch.







This function should not be used if there is a Central Control in the H-NET.

Installation

Indoor unit address

• Address Check Operation.



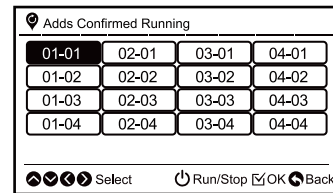
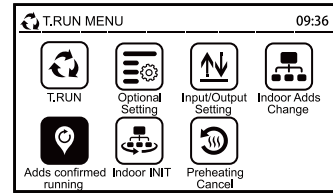

This function is used to check the relation between the indoor unit and I.U. address. This operation is effective when multiple indoor units are connected to the remote control switch and address of the certain unit is unknown.

1. Press and hold  (menu) and  (return) simultaneously for at least 3 seconds during the normal mode (when unit is not operated). The test run menu will be displayed.
2. Select 'Adds confirmed running' from the test run menu pressing $\wedge \vee < >$ and .
3. Select the indoor unit by pressing $\wedge \vee < >$.
4. To start operation of the indoor unit selected in (3) press  (run/stop). To return to (3) screen press  (run/ stop) while indoor units is operated.
- * Repeat (3)-(4) until desired indoor unit address is confirmed.
5. To return to the test run menu press  (return) while indoor unit is not operated.



• Indoor Unit Address Initialisation

This function initialises the indoor unit address that has been changed by 'Indoor Adds Change' function or set by the automatic address a location. Initialising the address will be changed to the dip switch setting.

1. Press and hold  (menu) and  (return) simultaneously for at least 3 seconds during the normal mode (when unit is not operated). The test run menu will be displayed.
2. Select 'Indoor INIT' from the test run menu pressing $\wedge \vee < >$ and $\wedge \vee < >$
3. Select the 'Reset Indoor Adds' by pressing $\wedge \vee$ and press .
4. Select the indoor unit by pressing $\wedge \vee < >$ and press . The confirmation screen will be displayed.

*Indoor units which are not supporting 'Reset Indoor Adds' function can not be selected.

The address of indoor unit that does not support 'Reset Indoor Adds' function will not be initialised even when 'All' is specified.

(5) Select 'Yes' and press  to start the address initialisation process.

*If the address initialisation is successfully completed, connection check will be started automatically.

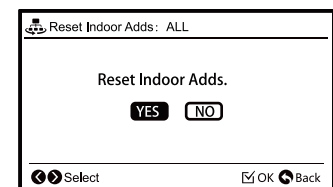
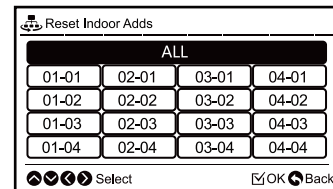
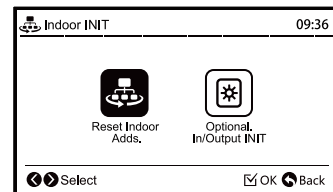
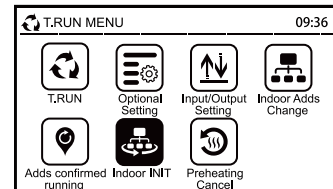

After sales service

If your air conditioning doesn't operate as normal, turn the unit and the power supply off immediately.

Contact your service center or technical department.

emerald.com.au/contact

Emerald Energy Pty Ltd

ABN 86 632 172 368

L2, 12a Rodborough Road Frenchs Forest NSW 2086