

# LED Panels

## Vanguard



### Features

- Affordable high-efficacy LED panel.
- No shadowing or aging.
- Flex and plug included.
- Flicker free external driver (LIFUD).
- Complies with AS 60598.2.5, ISTMT TM-21, C-TICK, AS 2293.

Using slimline back-lit technology, the Emerald Vanguard Panel provides the most efficient, reliable and affordable LED panel solution for commercial and office space applications. The Vanguard's technology allows light to naturally project through less material, ensuring the panel will not age or discolour over time.

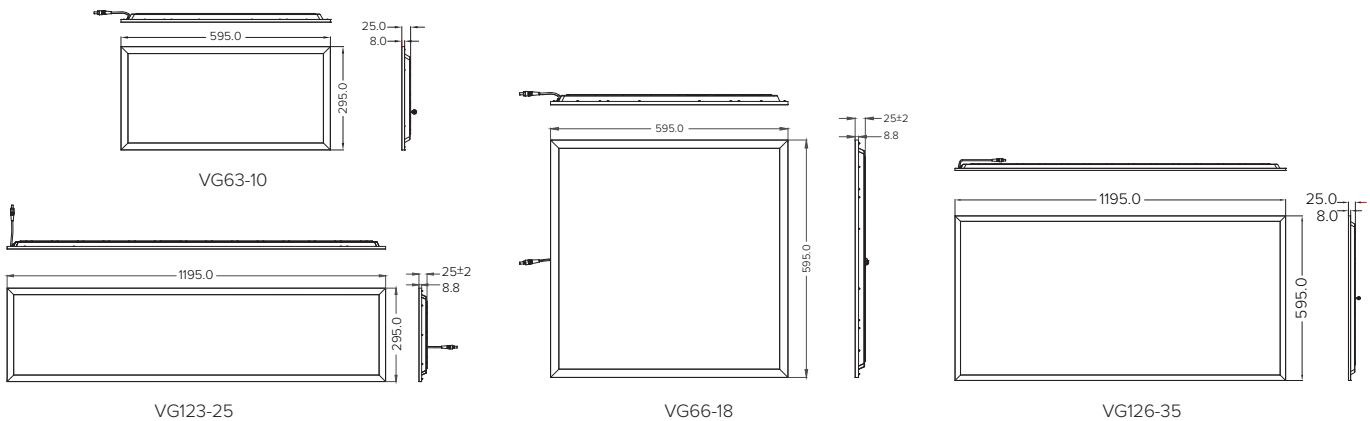
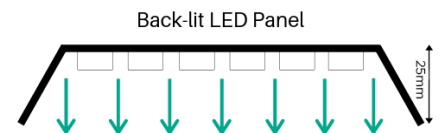

### Specifications

Power factor	>0.9
CRI	>80
Beam angle	120°
IP Rating	40
Lifetime (L70)	>60,000hrs
Warranty	5 years

Model	CCT	Dimensions (mm)	UGR	LCP	Sensor	Watt	Lumens	Efficacy (lm/W)
VG63-10	5000K	295x595x25	<22	10	No	10	1210	120.45
VG66-18	5000K	595x595x25	<22	17.34	No	18	2322	133.98
VG123-25	5000K	295x1195x25	<24	25.13	No	25	3173	126.24
VG126-35	5000K	595x1195x25	<22	34.82	No	35	4545	130.96

